



Atlas Copco



Oil-injected rotary screw compressors

GA 30+-90/GA 37-90 VSD (30-90 kW/40-125 hp)



Innovating for a sustainable future

At Atlas Copco, we have always looked ahead. Which products and services will make our customers more successful? Your future drives the Atlas Copco team every day. It is the reason why we devote so much time and so many resources to innovation. If there are technologies that will advance your productivity, we will find them. That is what we have been doing for almost 150 years now, setting new standards in compressed air reliability, efficiency, connectivity, and sustainability.

It's that last principle that now comes first. Sustainability is no longer something we should strive for, but something we must achieve. Productivity and growth will have to be built on sustainability. Atlas Copco – our products, our services, and our people – will help you get there, as we always have.

The technology that drives sustainability



Smart Temperature Control System

Calculates and achieves the ideal oil-injection temperature based on actual operating conditions to maximize efficiency.



Intelligent sensors

Constantly monitor the pressure drop and thus any energy losses in the inlet filter, the oil filter and the oil separator.

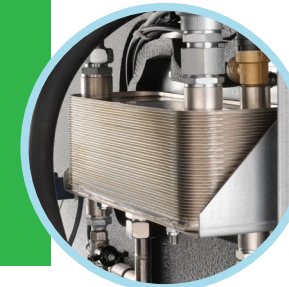

Energy recovery

Gives you additional energy savings by recovering and re-using up to 75% of the heat the compressor produces.



The ultimate smart solution, driven by efficiency



Atlas Copco's GA compressors bring you outstanding sustainability, reliability and performance, while minimizing the total cost of ownership. A choice of three premium compressor types (GA VSD, GA+ and GA) provides you with the compressed air solution that perfectly matches your requirements with clear value propositions. Built to perform even in the harshest environments, these compressors keep your production running efficiently.



GA 37-90 Premium performance

- High-performance Free Air Delivery.
- Premium quality at the lowest initial investment.
- Integrated refrigerant dryer.
- Elektronikon® Swipe controller (Elektronikon Touch on GA 90, optional for other GA models).
- LINK real-time, remote monitoring and optimization.



GA 30⁺-75⁺ Industry-leading efficiency

- Best-in-class Free Air Delivery.
- Lowest energy consumption for applications with a stable air demand.
- Intelligent features boost efficiency and reliability.
- Integrated refrigerant dryer.
- Elektronikon® Touch controller.
- **SMARTLINK** real-time, remote monitoring and optimization.



GA 37-90 VSD Ultimate energy savers

- Up to 35% energy savings.
- Industry-leading operating turndown range.
- Wide pressure selection: 4-13 bar.
- Start under system pressure, no blow-off.
- Integrated refrigerant dryer.
- In-house designed NEOS inverter.
- Elektronikon® Touch controller.
- **SMARTLINK** real-time, remote monitoring and optimization.

GA 37-90 VSD: Ultimate energy savers

When you are looking for efficiency, lowest cost of ownership and sustainability, the GA 37-90 VSD delivers the ultimate solution. The industry-leading oil-injected screw compressor with Variable Speed Drive technology generates energy savings of up to 35%. What is more, its innovative features give you a reliable performance in demanding conditions, longer service intervals, and advanced connectivity.

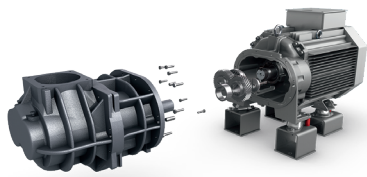

1

Maintenance-free drive system

- 100% maintenance-free; totally enclosed and protected against dirt and dust.
- Suitable for harsh environments.
- High-efficiency drive arrangement; no coupling or slippage losses.
- Standard up to 46°C/115°F and for high ambient version 55°C/131°F.

2

IE3 Premium Efficiency electrical motor

- IP55, insulation Class F, B rise.
- Non-drive side bearing greased for life.
- Designed for continuous operation in harsh environments.

3

Robust spin-on oil filter

- High-efficiency, removing 300% smaller particles than a conventional filter.
- Integrated bypass valve with the oil filter.



4

SIL Smart Inlet Lock system

- Superior designed vacuum and air pressure controlled valve with minimal pressure drop and no springs.
- Smart stop/start which eliminates back-pressure oil vapor.

11

Integrated highly efficient R410A dryer

- Excellence in air quality.
- 50% reduction in energy consumption compared to traditional dryers.
- Zero ozone depletion.
- Incorporates optional UD+ filter according to Class 1.4.2.

8

Elektronikon® Touch for remote monitoring

- Integrated smart algorithms reduce system pressure and energy consumption.
- Monitoring features include warning indications, maintenance scheduling and online visualization of machine condition.
- Standard **SMARTLINK** remote monitoring to maximize air system performance and energy savings.



5

Oil cooler and aftercooler for tropical environments

- Low element outlet temperatures, ensuring long oil lifetime.
- Removal of nearly 100% condensate with integrated mechanical separator.
- No consumables.
- Eliminates possibility of thermal shocks in coolers.

10

NEOS drive

- Atlas Copco's in-house designed inverter for GA VSD compressors.
- IP5X protection degree.
- A robust, aluminum enclosure for trouble-free operation in the harshest conditions.
- Fewer components: compact, simple and user-friendly.



9

Cubicle cooling booster

- Cubicle in overpressure minimizes ingress of conductive dust.
- Electrical components remain cool, enhancing lifetime of components.

7

Heavy-duty air intake filter

- Protects the compressor components by removing 99.9% of dirt particles down to 3 microns.
- Differential inlet pressure for proactive maintenance while minimizing pressure drop.

6

Electronic no-loss water drain

- Ensures constant removal of condensate.
- Manual integrated bypass for effective condensate removal in case of power failure.
- Integrated with compressor's Elektronikon® with warning/alarm features.



VSD: Driving down your energy costs

Over 80% of a compressor's lifecycle cost is taken up by the energy it consumes. Moreover, the generation of compressed air can account for more than 40% of a plant's total electricity bill. To cut your energy costs, Atlas Copco pioneered Variable Speed Drive (VSD) technology in the compressed air industry. VSD leads to major energy savings, while protecting the environment for future generations. Thanks to continual investments in this technology, Atlas Copco offers the widest range of integrated VSD compressors on the market.

Why Atlas Copco Variable Speed Drive technology?

- Up to 35% energy savings during fluctuations in production demand with an extensive turndown range.
- Integrated Elektronikon controller controls the motor speed and high efficiency frequency inverter.
- No wasted idling times or blow-off losses in normal operation.
- Compressor can start/stop under full system pressure without the need to unload with special VSD motor.
- Eliminates peak current penalty during start-up.
- Minimizes system leakage due to a lower system pressure.
- EMC compliance to directives (2004/108/EG).

In almost every production environment, air demand fluctuates depending on different factors such as the time of the day, week or even month. Extensive measurements and studies of compressed air demand profiles show that many compressors have substantial variations in air demand. Only 8% of all installations have a more stable air demand.

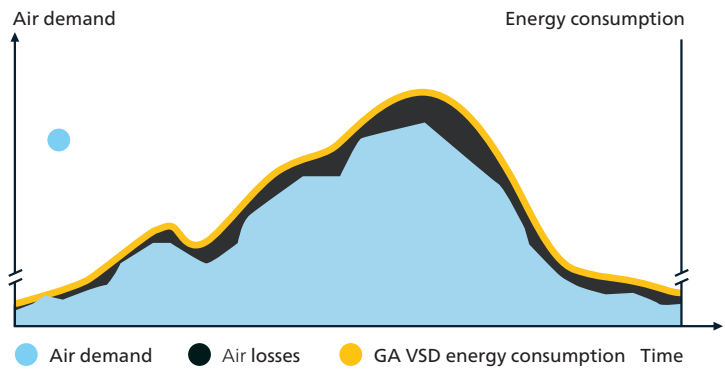
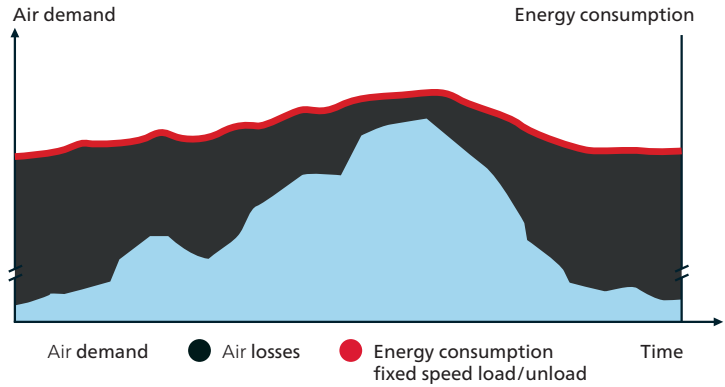

Up to 35% energy savings

Atlas Copco's GA VSD technology closely follows the air demand by automatically adjusting the motor speed. This results in up to 35% energy savings. The lifecycle cost of a compressor can be cut by an average of 22%. In addition, lowered system pressure with GA VSD dramatically minimizes energy use across your production.

Total compressor lifecycle cost

- Energy
- Investment
- Energy savings with VSD
- Maintenance

Real, reliable VSD technology

Atlas Copco did more than pioneer Variable Speed Drive compressors. We have always designed and developed them from scratch in-house. All components, not just the inverter, work together to deliver best-in-class VSD performance. That is why Atlas Copco VSD compressors so clearly outperform those pretend-VSD compressors that are merely retrofitted fixed-speed models with an add-on inverter. Because only a dedicated design and custom-built, quality components will get the most out of Variable Speed Drive technology. And only an Atlas Copco GA VSD will give you industry-leading energy savings, superior reliability and advanced connectivity.

GA 30⁺-75⁺: Industry-leading efficiency

The GA 30⁺-75⁺ is our fixed-speed oil-injected rotary screw compressor that sets the industry standard. It gives you more of the things that really matter: more energy savings, more air, and a longer lifetime. Its state-of-the-art compression element and a host of advanced features ensure maximum performance with best-in-class efficiency.

1

Maintenance-free drive system

- 100% maintenance-free; totally enclosed and protected against dirt and dust.
- Suitable for harsh environments.
- No coupling or slippage losses.
- Standard up to 46°C/115°F; high ambient version 55°C/131°F.

2

IE4 Super Premium Efficiency motor

- IP55, insulation Class F, B rise.
- Non-drive side bearing greased for life.
- Designed for continuous operation in harsh environments.

3

Robust spin-on oil filter

- High-efficiency; removes 300% smaller particles than a conventional filter.
- Integrated bypass valve with the oil filter.
- 8,000-hour service interval (GA 55⁺/GA 75⁺).

4

Oil cooler and aftercooler for tropical environments

- Low element outlet temperatures ensure long oil lifetime.
- Removal of nearly 100% of condensate with integrated mechanical separator.





5

Smart Thermostatic Control System (GA 55+/GA 75+)

- Intelligent algorithm achieves ideal injection temperature.
- Combines multiple operational parameters, including ambient temperature, pressure, humidity and load.
- Increases compressor efficiency and reliability.

6

Intelligent sensors (GA 55+/GA 75+)

- Pressure drop sensors monitor the lifetime of the inlet filter, the oil filter and the oil separator.
- CAN-cables allow for easy updates.



7

Elektronikon® Touch for remote monitoring

- High-tech controller with warning indications, compressor shut-down and maintenance scheduling.
- Standard SMARTLINK remote monitoring to maximize air system performance and energy savings.
- Optional multiple compressor control (2, 4 or 6 compressors).

8

Heavy-duty air intake filter (GA 55+/GA 75+)

- Protects compressor components by removing 99.9% of dirt particles down to 3 microns.
- Long 8,000-hour lifetime.

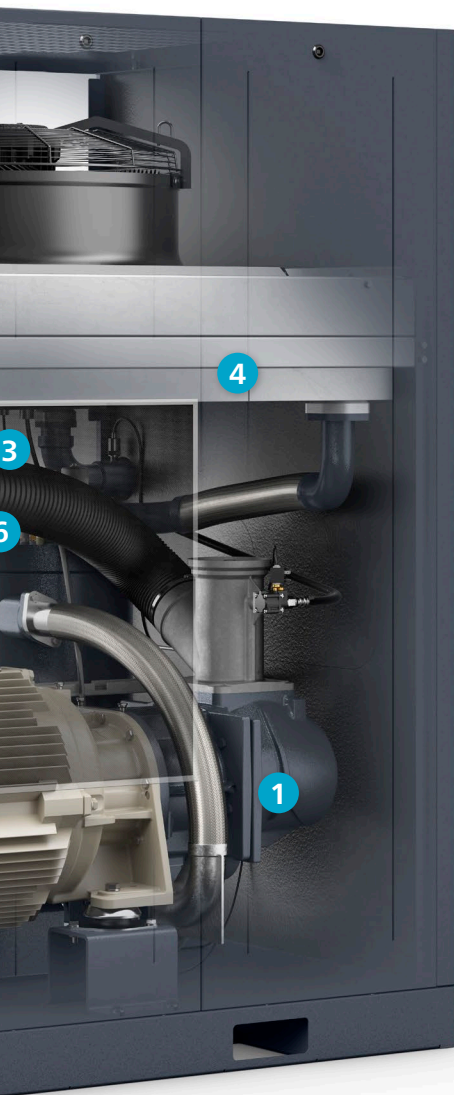

GA 55+/GA 75+ exclusive: Smart Temperature Control System

Our in-house developed Smart Temperature Control System introduces a new level of element efficiency and reliability. Its intelligent algorithm calculates the ideal oil-injection temperature based on parameters such as ambient and oil temperature, pressure and load, and air humidity. When necessary, the STC valve routes the oil via the coolers to achieve that ideal temperature to maximize compression efficiency and eliminate any risk of condensation.

GA 37-90: Premium performance

The GA 37-90 gives you that trusted Atlas Copco oil-injected screw performance at the lowest investment cost. Built with top-quality materials, the GA 37-90 ensures compressed air reliability and efficiency in the toughest conditions.

1

Maintenance-free drive system

- 100% maintenance-free; totally enclosed and protected against dirt and dust.
- Suitable for harsh environments.
- No coupling or slippage losses.
- Standard up to 46°C/115°F and for high ambient version 55°C/131°F.

2

IE3 Premium Efficiency electrical motor

- IP55, insulation Class F, B rise.
- Non-drive side bearing greased for life.
- Oil-lubricated drive side bearings.
- Designed for continuous operation in harsh environments.

3

Robust spin-on oil filter

- High-efficiency; removes 300% smaller particles than a conventional filter.
- Integrated bypass valve with the oil filter.

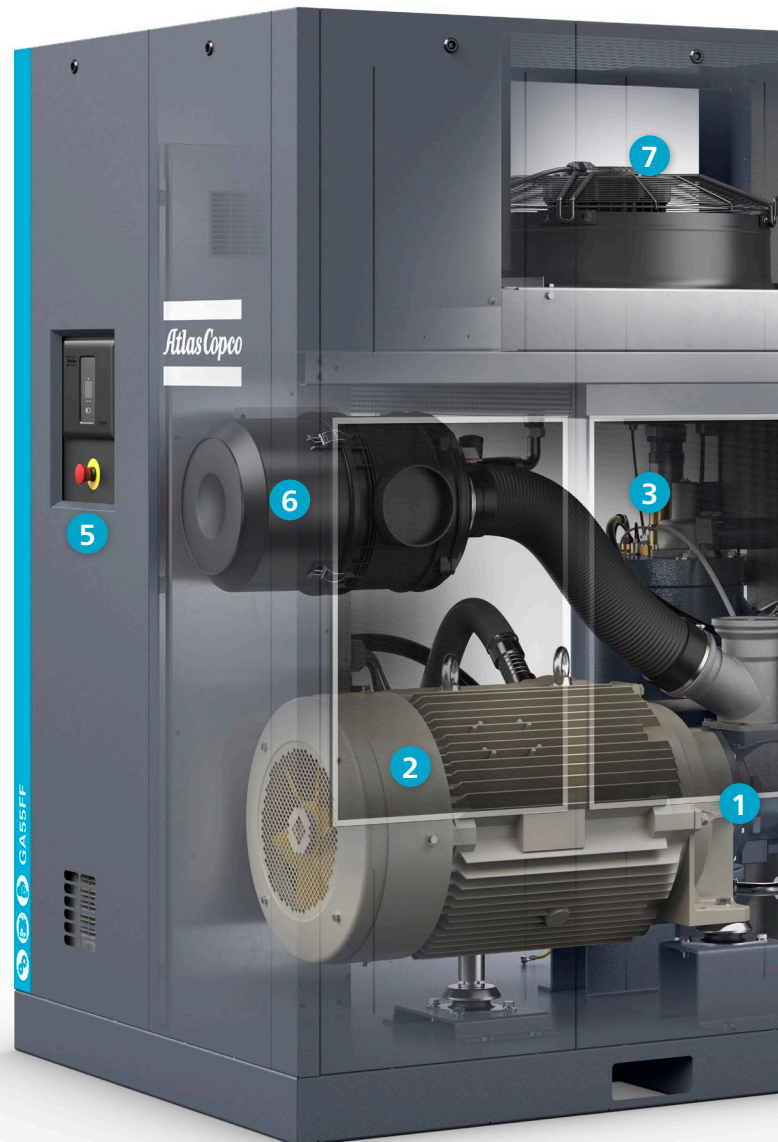

4

Oil cooler and aftercooler for tropical environments

- Low element outlet temperatures ensure long oil lifetime.
- Removal of nearly 100% of condensate with integrated mechanical separator.
- No consumables.
- Eliminates possibility of thermal shocks in coolers.

5

Advanced Elektronikon® control & monitoring

- Integrated smart algorithms reduce system pressure and energy consumption.
- Monitoring features include warning indications, maintenance scheduling, and online visualization of machine conditions.
- Standard **SMARTLINK** remote monitoring to maximize air system performance and energy savings.

6

Heavy-duty air intake filter

- Protects the compressor components by removing 99.9% of dirt particles down to 3 microns.
- Differential inlet pressure for proactive maintenance while minimizing pressure drop.

7

Low noise fan

- Silent operation.
- High flows.
- Compact design.

8

Integrated R410A dryer

- Excellence in air quality.
- 50% reduction in energy consumption compared to traditional dryers.
- Zero ozone depletion.
- Incorporates optional UD+ filter according to Class 1.4.2.

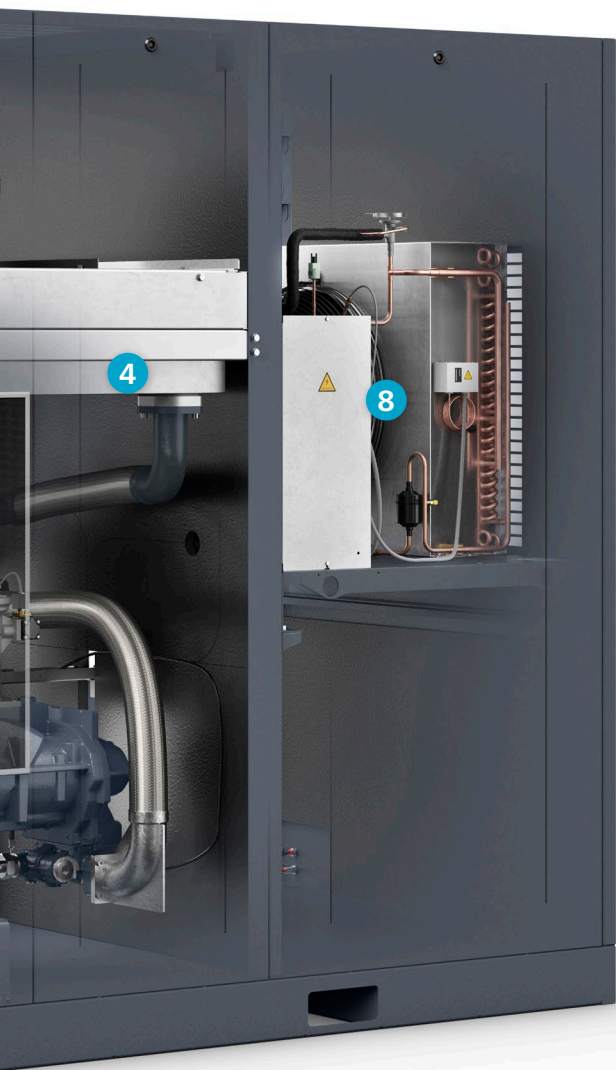

Advanced control for superior performance

The right controller



GA 37-90 VSD/GA 30+-75+: Elektronikon® Touch

- Ease of use: 4.3-inch high-definition color display with clear pictograms and service indicator.
- Reliable: user-friendly, multilingual user interface and durable keyboard.
- Flexible: four different week schedules for 10 consecutive weeks.
- Internet-based compressor visualization with a simple Ethernet connection.
- Remote control and connectivity functions.



GA 37-90: Elektronikon® Swipe

- Ease of use: intuitive navigation with clear pictograms and extra LED indicator for service.
- Visualization through web browser with a simple Ethernet connection.
- Easy to upgrade.

SMARTLINK

SMARTLINK brings real-time monitoring of your compressor's operational parameters to your computer or mobile device:

- Performance data and insights identify opportunities for optimization.
- Service timeline.
- Maintenance and service alerts.
- Online resource center with manuals, documentation and technical information.

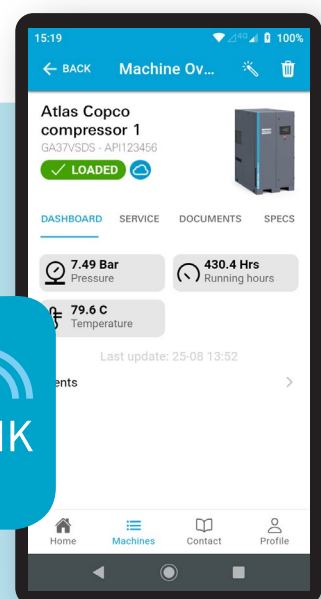

Flexible control and monitoring features

The next-generation Elektronikon controllers offer a great variety of control and monitoring features that allow you to increase your compressor's efficiency and reliability, including automatic restart after voltage failure, Delayed Second Stop, Dual Pressure Set Point, and multiple compressor control.

Multiple compressor control

Manage and optimize up to 6 compressors in one air network with the Equalizer 4.0 (integrated in your compressor or as a standalone unit).

Delayed Second Stop (DSS)

The DSS feature stops the compressor's motor whenever possible. The controller maintains the desired system pressure while minimizing the motor run time to keep your energy consumption at a minimum.

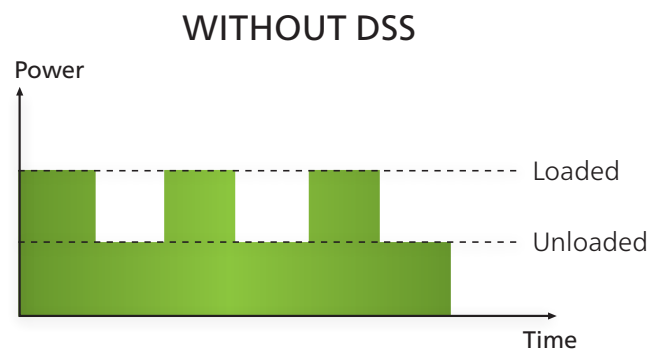
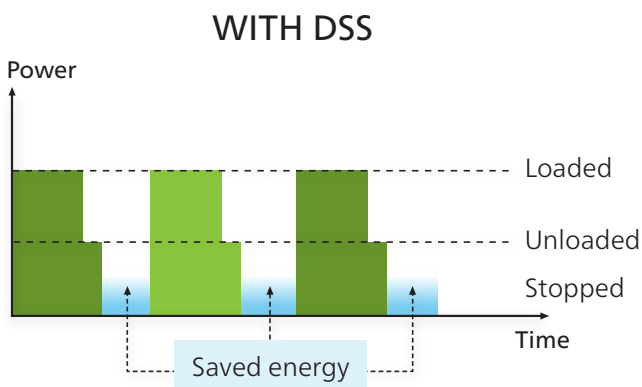
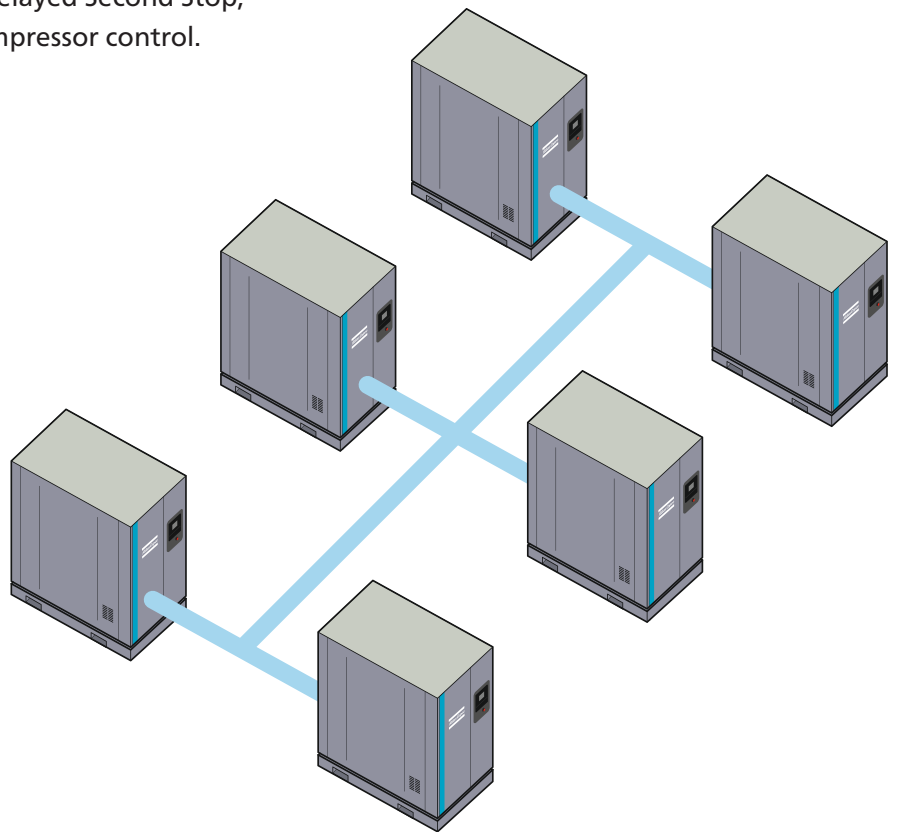

Built-in quality air

Untreated compressed air contains moisture, aerosols and dirt particles that can damage your air system, creating the risk of corrosion and leaks, and contaminate your end product. Maintenance and repair expenses can far exceed air treatment costs. An air dryer is therefore essential to protect your systems and processes. The GA, GA+, and GA VSD have an integrated dryer option to ensure your peace of mind.

A fully integrated dryer

- Optimized sizing for the compressor avoids excessive energy consumption.
- Fit for your application.
- Controlled and monitored by the Elektronikon®.
- Space-saving all-in-one solution with low installation costs.



Lowest lifecycle costs and peace of mind

- No extra installation costs.
- Save on floor space.
- Use of energy-efficient, environmentally friendly refrigerant R410A reduces operating costs and ensures zero ozone depletion.
- Heat exchanger cross-flow technology with low pressure drop, saving energy and costs.
- Zero waste of compressed air thanks to no-loss condensate drain.
- Advanced control functions ensure dry air under all circumstances and prevent freezing at low load.
- Pressure dewpoint of 3°C/37°F (100% relative humidity at 20°C/68°F).

Integrated purity

The optional UD+ filter and integrated refrigerant air dryer (IFD) efficiently remove moisture, aerosols and dirt particles to protect your investment. The UD+ filter has a 40% lower pressure drop than the conventional DD+/PD+ filter combination. It saves space and reduces energy costs. Using only 1 single filter, it is possible to reach Quality Class 1.4.2 according to ISO 8573-1:2010.

	ISO quality class*	Dirt particle size	Water pressure dewpoint**	Oil concentration
Pack compressor	3.-4	5 microns	-	3 ppm
Integrated refrigerant dryer	3.4.4	5 microns	+3°C/37°F	3 ppm
UD+	1.4.2	0.5 micron	+3°C/37°F	0.1 ppm

* The table values reflect the maximum limits according to the ISO quality air standard (ISO 8573-1:2010).

** Water pressure dewpoint based on 100% RH at 20°C/68°F.

Built-in energy recovery

As much as 90% of the electrical energy used by a compressed air system is converted into heat. Why let that heat go to waste? A specifically developed energy recovery system can be built into your GA, GA+, and GA VSD, allowing you to recover up to 75% of that power input as hot air or hot water (e.g.: changing room showers). Through efficient use of the recovered energy, you generate important energy cost savings and a high return on investment without compromising your compressor's performance.

Use your compressor twice

Hot water

Convert compressor heat into hot water for:

- Radiators
- Laundries, industrial cleaning and sanitary facilities
- Industrial process heating
- Canteens and large kitchens
- Food, chemical and pharmaceutical industries



Ducting

Recovered hot air can be used for:

- Auxiliary or main heating of warehouses and workshops
- Drying processes



Options

Some applications may need or may benefit from additional options and more refined control/air treatment systems. To meet these needs, Atlas Copco has developed options and easily integrated compatible equipment.

		GA 30*-45	GA 37*-45*	GA 55-90	GA 55*-75*	GA 37-90 VSD
Air treatment	Integrated filter kit class 1*	•	•	•	•	•
	Dryer bypass*	-	-	-	-	•
Protection	Phase sequence relay (GA 55-90)	■	■	■	■	NA
	Tropical thermostat	■	■	■	■	■
	Pre-filter	■	■	■	■	■
	Advanced monitoring	•	•	•	■	-
Public works	Main power isolator switch	•	•	•	•	•
Communication	Elektronikon® Touch upgrade (only for GA)	•	■	•	■	■
	EQ2i/EQ4i/EQ6i	•	•	•	•	•
Oils	Roto Synthetic Xtend oil (8,000 hours)	-	-	-	■	-
General options	Witness performance test	•	•	•	•	•
	Energy recovery	•	•	•	•	•

* FF units only.

■ : Standard • : Optional - : Not available

Flow charts

Variable Speed Drive: GA VSD

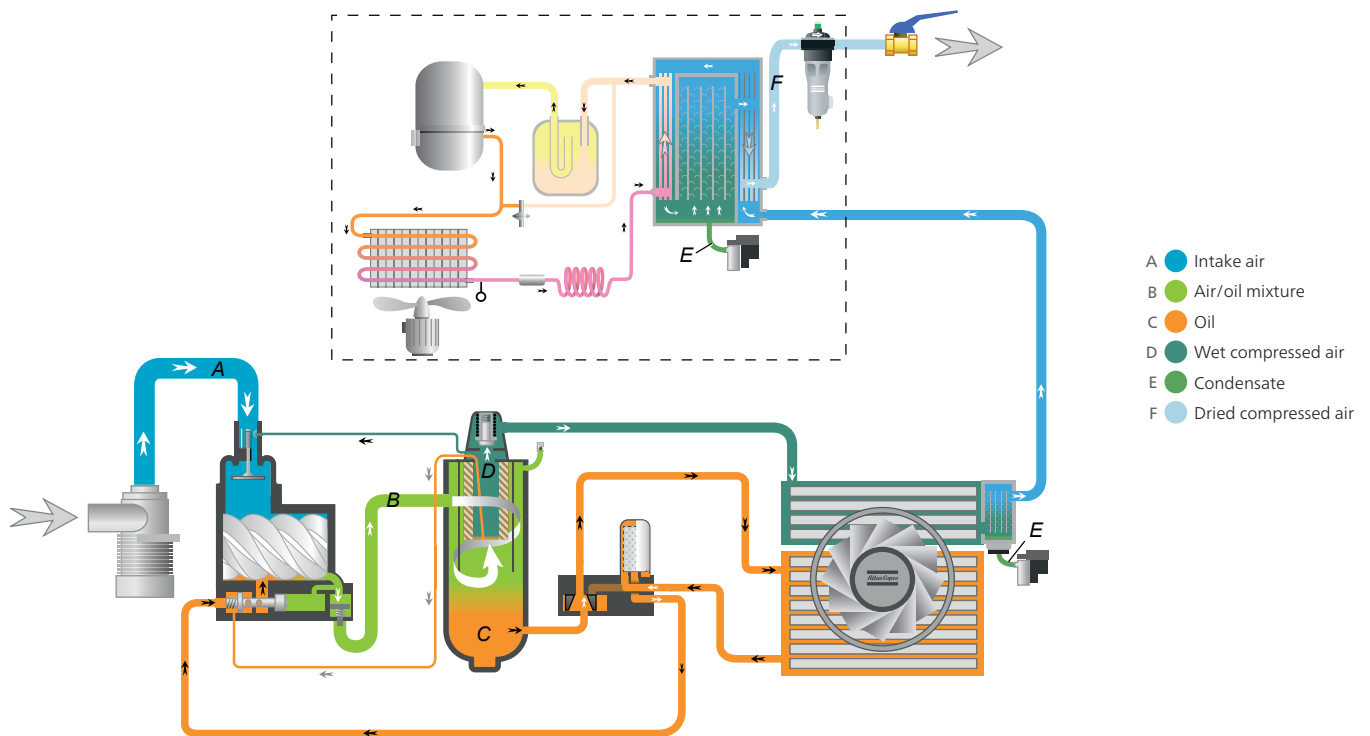

Fixed-speed: GA+ & GA

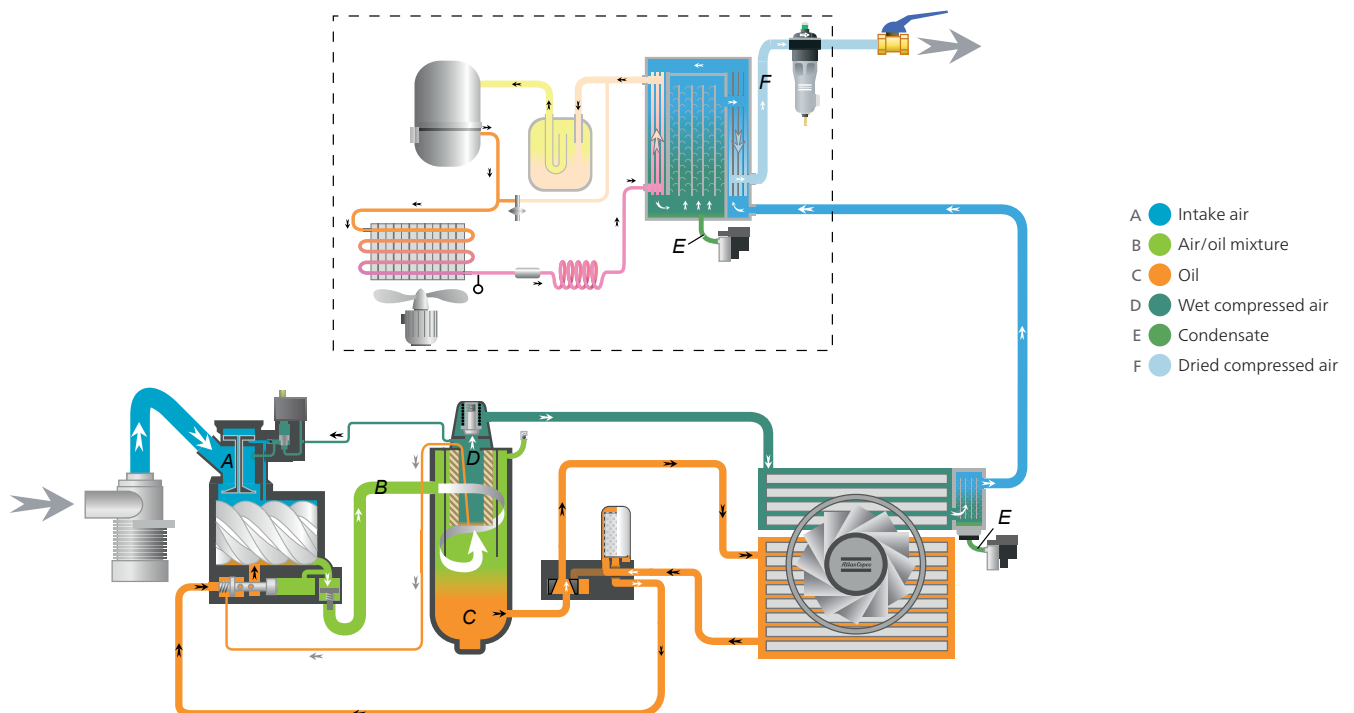

Technical specifications GA 30+-90

Compressor type	Pressure variant	Max. working pressure Pack		Capacity FAD*			Installed motor power		Noise level**	Weight Pack		Weight Full Feature	
		bar(e)	psig	l/s	m ³ /min	cfm	kW	hp		kg	lbs	kg	lbs
GA 30+	7.5	7.5	109	99	5.9	210	30	40	69	836	1839	796	1751
	8.5	8.5	123	90	5.4	191	30	40	69	836	1839	796	1751
	10	10	152	82	4.9	174	30	40	69	836	1839	796	1751
GA 37	7.5	7.5	109	115	6.9	244	37	50	75	823	1811	887	1951
	8.5	8.5	123	106	6.4	225	37	50	75	823	1811	887	1951
	10	10	152	100	6.0	212	37	50	75	823	1811	887	1951
GA 37+	7.5	7.5	109	122	7.3	259	37	50	69	914	2011	1049	2308
	8.5	8.5	123	118	7.1	250	37	50	69	914	2011	1049	2308
	10	10	145	102	6.1	216	37	50	69	914	2011	1049	2308
GA 45	7.5	7.5	109	137	8.2	290	45	60	75	958	2108	1022	2248
	8.5	8.5	123	127	7.6	269	45	60	75	958	2108	1022	2248
	10	10	152	117	7.0	248	45	60	75	958	2108	1022	2248
GA 45+	7.5	7.5	109	149	8.9	316	45	60	69	962	2116	1102	2424
	8.5	8.5	123	139	8.3	295	45	60	69	962	2116	1102	2424
	10	10	145	128	7.7	271	45	60	69	962	2116	1102	2424
GA 55	7.5	7.5	109	182	10.9	386	55	75	75	1305	2871	1775	3905
	8.5	8.5	123	174	10.4	369	55	75	75	1305	2871	1775	3905
	10	10	152	159	9.5	337	55	75	75	1305	2871	1775	3905
GA 55+	7.5	7.5	109	198	11.9	421	55	75	71	1390	3058	1860	4092
	8.5	8.5	123	182	10.9	386	55	75	71	1390	3058	1860	4092
	10	10	152	164	9.8	348	55	75	71	1390	3058	1860	4092
GA 75	7.5	7.5	109	236	14.2	500	75	100	75	1385	3047	1855	4081
	8.5	8.5	123	226	13.6	479	75	100	75	1385	3047	1855	4081
	10	10	152	208	12.5	441	75	100	75	1385	3047	1855	4081
GA 75+	7.5	7.5	109	258	15.5	547	75	100	71	1515	3333	1985	4367
	8.5	8.5	123	240	14.4	509	75	100	71	1515	3333	1985	4367
	10	10	152	220	13.2	466	75	100	71	1515	3333	1985	4367
GA 90	7.5	7.5	109	287	17.2	608	90	125	75	1535	3377	1980	4356
	8.5	8.5	123	279	16.7	591	90	125	75	1535	3377	1980	4356
	10	10	152	252	15.1	534	90	125	75	1535	3377	1980	4356
	13	13	189	216	13.0	458	90	125	75	1535	3377	1980	4356

* Unit performance measured according to ISO 1217, Annex C, Edition 4:2009.

** A-weighted emission sound pressure level at the work station, Lp WSA (re 20 µPa) dB (with uncertainty 3 dB).

Values determined according to noise level test code ISO 2151 and noise measurement standard ISO 9614.

FAD is measured at the following working pressures:

- 7.5 bar versions at 7 bar
- 8.5 bar versions at 8 bar
- 10 bar versions at 9.5 bar
- 13 bar versions at 12.5 bar

Reference conditions:

- Absolute inlet pressure 1 bar (14.5 psi)
- Intake air temperature 20°C/68°F

Pressure dewpoint of integrated refrigerant dryer at reference conditions:
3°C, 37°F

Dimensions



Dimensions	Pack						Full Feature					
	L (mm)	W (mm)	H (mm)	L (in)	W (in)	H (in)	L (mm)	W (mm)	H (mm)	L (in)	W (in)	H (in)
GA 30*/37/45	1,335	970	1,800	52.6	38.2	70.9	1,765	970	1,800	69.5	38.2	70.9
GA 37*/45+	1,335	970	1,800	52.6	38.2	70.9	1,765	970	1,800	69.5	38.2	70.9
GA 55*/75*/55/75/90	1,680	1,221	1,980	66.1	48.1	78.0	2,524	1,221	1,980	99.4	48.1	78.0
GA 55/75/90 VSD	2,250	1,080	2,105	88.6	42.5	82.9	2,250	1,080	2,105	88.6	42.5	82.9

Technical specifications GA 37-90 VSD

Compressor type	Working pressure		Capacity FAD*						Installed motor power		Noise level**	Weight Pack		Weight Full Feature	
			l/s		m ³ /min		cfm								
	bar(e)	psig	min	max	min	max	min	max	kW	hp	dB(A)	kg	lbs	kg	lbs
GA 37 VSD	4	58	26.0	124	1.6	7.4	55	263	37	50	66/67	1042	2297	1127	2485
	7	102	26.0	123	1.6	7.4	55	261	37	50	66/67	1042	2297	1127	2485
	10	145	25.8	107	1.6	6.4	55	227	37	50	66/67	1042	2297	1127	2485
	13	189	40.3	87	2.4	5.2	85	184	37	50	66/67	1042	2297	1127	2485
GA 45 VSD	4	58	26.0	146	1.6	8.8	55	309	45	60	69/72	1100	2425	1190	2624
	7	102	26.0	145	1.6	8.7	55	307	45	60	69/72	1100	2425	1190	2624
	10	145	25.8	128	1.6	7.7	55	271	45	60	69/72	1100	2425	1190	2624
	13	189	40.3	107	2.4	6.4	85	227	45	60	69/72	1100	2425	1190	2624
GA 55 VSD	4	58	26.0	177	1.6	10.6	55	375	55	75	69/72	1380	3042	1480	3263
	7	102	26.0	175	1.6	10.5	55	371	55	75	69/72	1380	3042	1480	3263
	10	145	25.4	155	1.5	9.3	54	328	55	75	69/72	1380	3042	1480	3263
	13	189	37.0	129	2.2	7.7	78	273	55	75	69/72	1380	3042	1480	3263
GA 75 VSD	4	58	37.2	245.7	2.4	15.2	78	522	75	100	69/70	1534	3382	1654	3646
	7	102	36.8	245.9	2.3	15.1	78	522	75	100	69/70	1534	3382	1654	3646
	10	145	47.3	215.9	2.9	13.1	100	458	75	100	69/70	1534	3382	1654	3646
	13	189	57.4	179.2	3.5	10.9	122	263	75	100	69/70	1534	3382	1654	3646
GA 90 VSD	4	58	36.6	290.1	2.5	17.7	78	615	90	125	73/74	1534	3382	1654	3646
	7	102	39	289	2.4	17.6	83	613	90	125	73/74	1534	3382	1654	3646
	10	145	47.8	254.4	2.9	15.4	101	540	90	125	73/74	1534	3382	1654	3646
	13	189	58.8	211.9	3.6	12.8	125	450	90	125	73/74	1534	3382	1654	3646

* Unit performance measured according to ISO 1217, Annex E, Edition 4:2009. Maximum working pressure for VSD machines: 13 bar(e) (188 psig).
 ** A-weighted emission sound pressure level at the work station, Lp WSA (re 20 µPa) dB (with uncertainty 3 dB). Values determined according to noise level test code ISO 2151 and noise measurement standard ISO 9614.

